

# TRANSIT LIGHT BOX SPECIFICATION FORM

DATE \_\_\_\_\_

COMPANY \_\_\_\_\_ CONTACT \_\_\_\_\_

PHONE # \_\_\_\_\_ FAX# \_\_\_\_\_ P.O. NUMBER \_\_\_\_\_

**SINGLE SIDED**

4" DEEP   
BACK-LIT LED

4" DEEP   
BACK-LIT  
LINEAR FLUORESCENT

**DOUBLE SIDED**

8" DEEP   
BACK-LIT LED

8" DEEP   
BACK-LIT  
LINEAR FLUORESCENT

QUANTITY

DATE REQUIRED

UNIT PRICE

DEPOSIT AMOUNT

APPROX. SHIPPING COST

INDOOR  OUTDOOR  BLACK PAINTED  OTHER COLOR \_\_\_\_\_

**CLEAR PLASTIC COVER:** GLASS  PLEXIGLASS  POLYCARBONATE   
**SPECIFY THICKNESS**

TRANSIT BOX OUTSIDE DIMENSIONS                      TRANSIT BOX INSERT SIZE

HEIGHT \_\_\_\_\_ LENGTH \_\_\_\_\_                      HEIGHT \_\_\_\_\_ LENGTH \_\_\_\_\_

PLEASE INDICATE THE CRITICAL DIMENSIONS OUTSIDE OR INSERT SIZE

OTHER INSTRUCTIONS: \_\_\_\_\_

**PLEASE INDICATE THE FOLLOWING ON THE DRAWING:**

CORD LOCATION    SWITCH LOCATION    HINGED SIDE    LOCK(S)

**Front View**

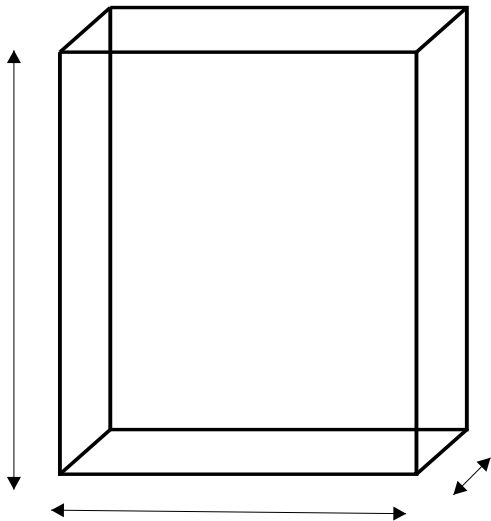

**Back View**

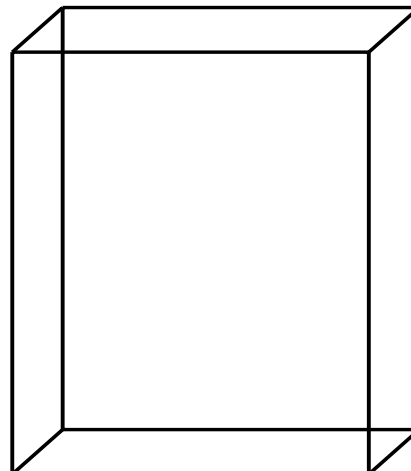

\_\_\_\_\_  
**Name of Purchaser**

\_\_\_\_\_  
**Signature of Purchaser**